

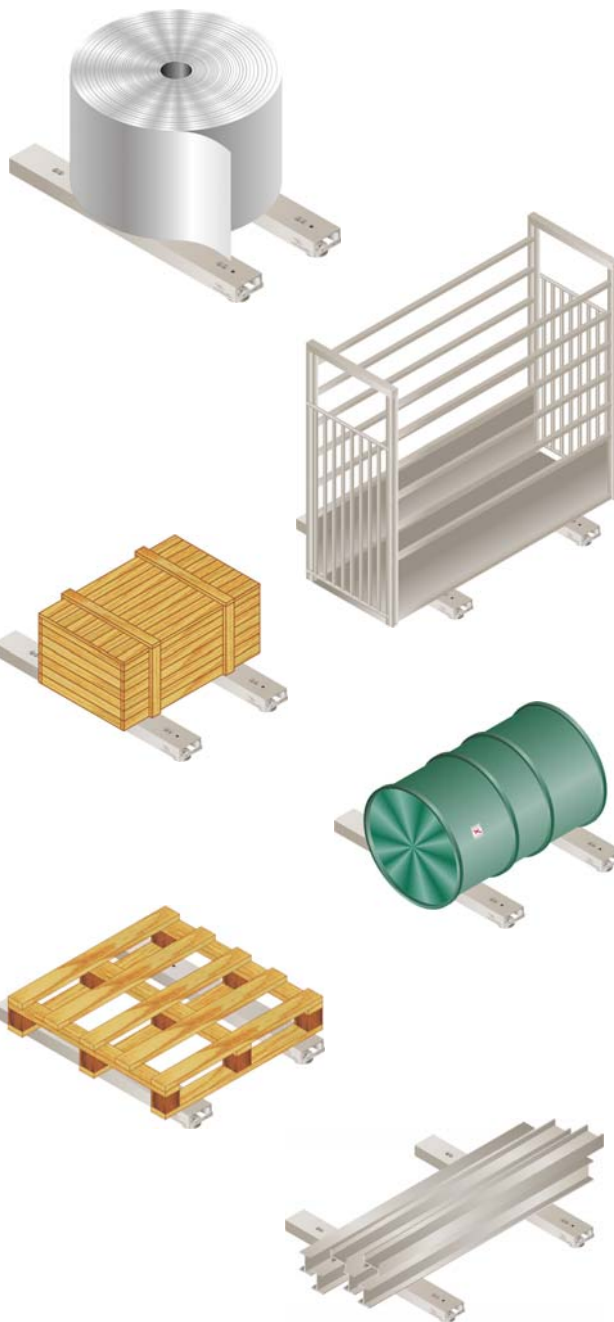

Example applications



Range of use

Weighing bars in the R2 range are adapted to weighing most packagings for the material.

They are designed to perform a large number of weighing applications through the possible combination of all weighing indicators and transmitters in the PRECIA-MOLEN range.

Range

There are only four capacities of R2 weighing bars for **internal** (non-trade use).

- 300 kg / 100 g
- 600 kg / 200 g
- 1 500 kg / 500 g
- 2 t / 1 kg

Every model in the range is available in painted steel version only.

Standard delivery contents

Weighing bars in the R2 range are delivered in pairs and are equipped with a 3 m cable between bars and a 6 m connection cable to the indicator.



Physical characteristics

I x w	Dimensions		Weight
		Height	
1 260 x 140 mm	81-89 mm	27 kg environ	
1 260 x 140 mm	81-89 mm	27 kg environ	
1 260 x 140 mm	81-89 mm	27 kg environ	
1 260 x 140 mm	81-89 mm	27 kg environ	

Metrological characteristics (non-trade use)

Model		Tare offset	Load cells	
Capacity	Division		E max.	V min.
300 kg	100 g	1 500 kg	500 kg	50 g
600 kg	200 g	1 500 kg	1 000 kg	100 g
1 500 kg	500 g	600 kg	1 000 kg	100 g
2 000 kg	1 kg	200 kg	2 000 kg	200 g

Options & Accessories

Wheels

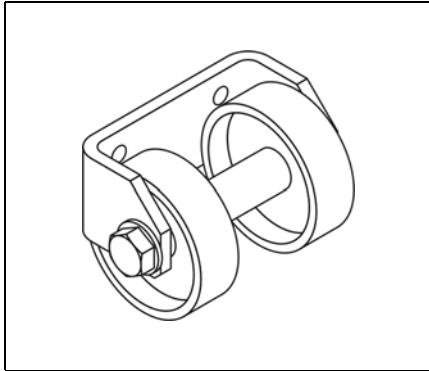

Fixing plates

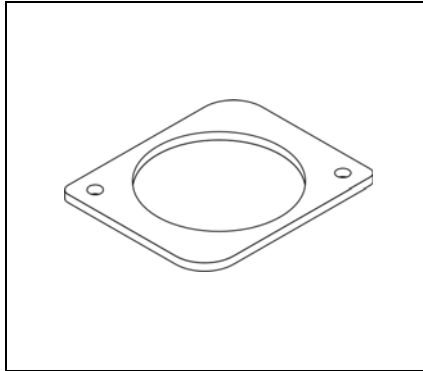

Other options

- 6 m cable between bars.
- Stainless steel load cells.

You weighing specialist



Illustrations are not contractual. Precia-Molen reserves the right to modify at any time, without prior notice, the information contained in this leaflet.

Offices and Factory
 P.O. Box 106 - 07000 Privas - FRANCE
 Tél. 33 (0) 475 664 600
 Fax 33 (0) 475 658 330
 E-MAIL webmaster@preciamolen.com
 RCS : 386 620 165 RCS Aubenas

