



R1 GM



R1 GM-S

## R1 GM

### Models

Platform size (mm)	Weighing capacity	Division	ML	Platform size (mm)	Weighing capacity	Division	ML
400 x 400	15/30 kg	5/10 g	●	600 x 600	60 kg	2 ou 5 ou 10 g	
	30 kg	1 ou 2 ou 5 g			60 kg	20 g	●
	30 kg	10 g	●		150 kg	5 ou 10 g	
	60 kg	2 ou 5 ou 10 g			150 kg	50 g	●
	60 kg	20 g	●		60/150 kg	20/50 g	●
	30/60 kg	10/20 g	●		60 kg	2 ou 5 ou 10 g	
	150 kg	5 ou 10 g			60 kg	20 g	●
500 x 400	150 kg	50 g	●	800 x 600	60/150 kg	20/50 g	●
	60/150 kg	20/50 g	●		150 kg	5 ou 10 g	
	15/30 kg	5/10 g	●		150 kg	50 g	●
	30 kg	1 ou 2 ou 5 g			300 kg	10 ou 20 ou 50 g	
	30 kg	10 g	●		300 kg	100 g	●
	60 kg	2 ou 5 ou 10 g			150/300 kg	50/100 g	●
	60 kg	20 g	●				
30/60 kg	10/20 g	●					
150 kg	5 ou 10 g						
150 kg	50 g	●					
60/150 kg	20/50 g	●					

### Application Composition

Especially designed for intensive use, PRECIA-MOLEN's R1 GM range of platform scales are equipped with a single point load cell making them extremely reliable and ensuring optimum accuracy. They are suitable for table-top, work bench or floor installation.

The new technology applied to this range of platform scales provides a lighter yet more robust construction when compared to conventional scales of this type.

The R1 GM scale platform is available in two versions : steel (Std) and stainless steel (Ti) in four platform sizes : 400 x 400 mm, 500 x 400 mm, 600 x 600 mm and 800 x 600 mm. The 400 x 400 and 500 x 400 models are fitted with a stainless steel plate as standard.

The standard IP 54 version is constructed in mild steel and has a polyurethane lacquer finish.

The Ti IP 67 version is entirely constructed in stainless steel type 304 L and is equipped with a stainless steel load cell (except 800 x 600 is equipped with a "self-curing", aluminium load cell).

The R1 GM platform scales may be combined with a selection of PRECIA-MOLEN indicators for trade (3,000 e or 2 x 3,000 e) or non trade applications.

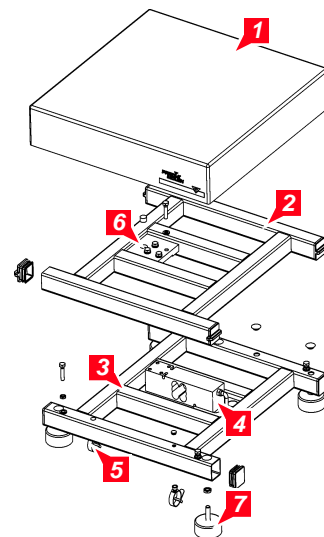

1. Lacquered steel (Std) or stainless steel (Ti) platform.
2. Lacquered steel (Std) or stainless steel 304-L (Ti) platform bearer.
3. Lacquered steel (Std) or stainless steel 304-L (Ti) frame.
4. Load cell.
5. Roller for cable.
6. Spirit level.
7. Adjustable feet.

### European Conformity

Compliant with the definition of a conventional load receptor in accordance with the guide WELMEC 2.4.

### Option

Ex version for a use in gaseous and dusty potentially explosive zone in accordance with the directive 94/09/CE.

**Marking** : EEx ia IIC T6 II2G Ex ia D21 T100°C II2D.

**Technical characteristics : standard version**

Model - L x l (mm)	Weighing capacity	Division	Load cell		Centre-to-centre distance of feet	Height		Weight	Max. dead load
			E max	V min		Min.	Max.		
400 x 400 ML	30 kg	10 g	100 kg	5 g	346 x 330 mm	102 mm	110 mm	10 kg	50 kg
	60 kg	20 g	200 kg	10 g					100 kg
	150 kg	50 g	200 kg	10 g					15 kg
500 x 400 ML	30 kg	10 g	100 kg	5 g	346 x 330 mm	102 mm	110 mm	12 kg	50 kg
	60 kg	20 g	200 kg	10 g					100 kg
	150 kg	50 g	200 kg	10 g					15 kg
600 x 600 ML	60 kg	20 g	150 kg	20 g	530 x 508 mm	149 mm	155 mm	34 kg	60 kg
	150 kg	50 g	200 kg	50 g					10 kg
800 x 600 ML	60 kg	20 g	150 kg	20 g	530 x 708 mm	149 mm	155 mm	36 kg	50 kg
	150 kg	50 g	200 kg	50 g					5 kg
	300 kg	100 g	500 kg	100 g					100 kg

**Technical characteristics : stainless steel version**

Model - L x l (mm)	Weighing capacity	Division	Load cell		Centre-to-centre distance of feet	Height		Weight	Max. dead load
			E max	V min		Min.	Max.		
400 x 400 (Stainless steel load cell)	30 kg	10 g	50 kg	5 g	346 x 330 mm	104 mm	112 mm	10 kg	13 kg
	60 kg	20 g	100 kg	10 g					30 kg
	150 kg	50 g	200 kg	20 g					20 kg
500 x 400 (Stainless steel load cell)	30 kg	10 g	50 kg	5 g	346 x 330 mm	104 mm	112 mm	12 kg	10 kg
	60 kg	20 g	100 kg	10 g					25 kg
	150 kg	50 g	200 kg	20 g					15 kg
600 x 600 (Stainless steel load cell)	60 kg	20 g	100 kg	10 g	530 x 508 mm	149 mm	155 mm	34 kg	10 kg
	150 kg	50 g	200 kg	20 g					0 kg
800 x 600 (Load cell PR)	60 kg	20 g	100 kg	20 g	680 x 535 mm	135 mm	160 mm	43 kg	0 kg
	150 kg	50 g	250 kg	50 g					50 kg
	300 kg	100 g	500 kg	100 g					100 kg

**Extent of standard supply**

The load receivers of R1 GM range are delivered with 3m cable (except models 400 x 400 and 500 x 400 Std : 1 m 50 cable) for the connection to an indicator. Installation manual supplied.

**Options & Accessories**

- Column for indicator
  - Height 240, 390 and 525 mm
- Junction box CPL1
  - Also available: measuring cable

**Your weighing specialist**

Illustrations are not contractual. Precia-Molen reserves the right to modify at any time, without prior notice, the information contained in this leaflet.

Offices and Factory  
 P.O. Box 106 - F 07000 Privas - France  
 Tel. 33 (0) 475 664 600  
 Fax 33 (0) 475 658 330  
 E-MAIL webmaster@preciamolen.com

RCS : 386 620 165 RCS Aubenas

